

**BEDIENUNGSANLEITUNG**

UNIVERSALKIT FÜR DEN ABZUG DER DEFEKTEN ZÜNDKERZEN  
M8X1, M9X1, M10X1 UND M10X1,25

**INSTRUCTION MANUAL**

UNIVERSAL SET FOR REMOVING GLOW PLUGS  
M8X1, M9X1, M10X1 AND M10X1,25

**MODE D'EMPLOI**

KIT UNIVERSEL POUR L'EXTRACTION DES BOUGIES CASSÉES  
M8X1, M9X1, M10X1 ET M10X1,25

**ISTRUZIONI OPERATIVE**

KIT UNIVERSALE PER L'ESTRAZIONE DELLE CANDELETTE ROTTE  
M8X1, M9X1, M10X1 E M10X1,25

**INSTRUCCIONES DE USO**







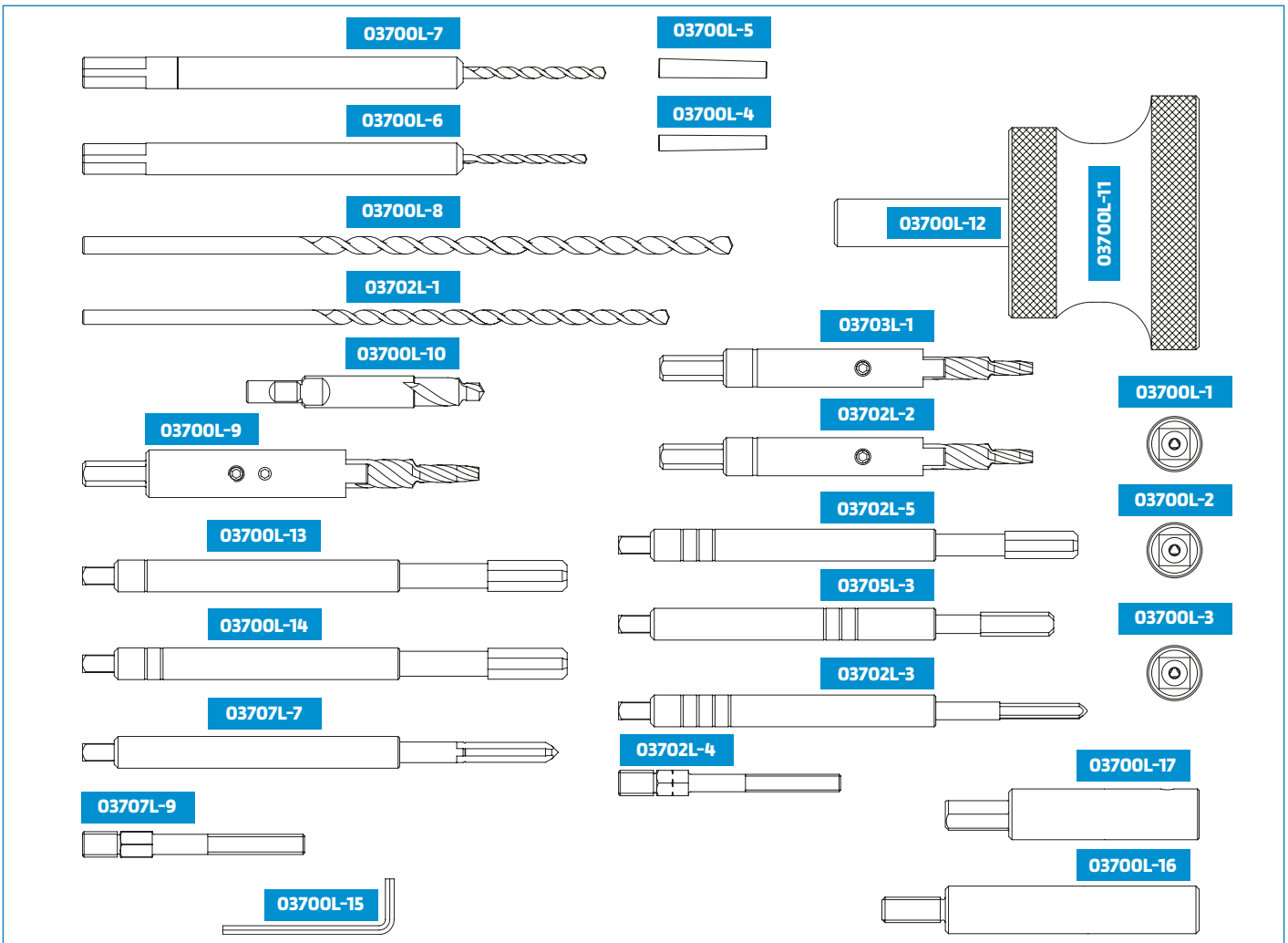









KIT UNIVERSAL PARA LA EXTRACCIÓN DE BUJÍAS ROTAS  
M8X1, M9X1, M10X1 Y M10X1,25



## BESTANDTEILE



Bez.	Beschreibung	
03700L-1	Abzugsbuchse Ø 2.5 mm	
03700L-2	Abzugsbuchse Ø 3.5 mm	
03700L-3	Abzugsbuchse Ø 4 mm	
03700L-4	Führungsröhrchen für Bohrung Ø 2.7 mm	
03700L-5	Führungsröhrchen für Bohrung Ø 3.6 mm	
03700L-6	Verlängerung + Spitze Ø 2.7 mm	
03700L-7	Verlängerung + Spitze Ø 3.6 mm	
03700L-8	Zylindrischer Spiralbohrer Ø 5.5 mm	
03700L-9	Verlängerung + Spitze Ø 8.9 - Ø 5.5 mm	
03700L-10	Bohrspitze mit zwei Durchmessern Ø 8.9 - Ø 5.5 mm kurz	

Bez.	Beschreibung	
03700L-11	Schlagwerkhammer	
03700L-12	Stift M8 für Schlagmaschine	
03700L-13	Gewindezapfen M10x1	
03700L-14	Gewindezapfen M10x1.25	
03700L-15	Inbusschlüssel 2.5 mm	
03700L-16	Verlängerung Ø 15 mm für Abzugszapfen	
03700L-17	Verlängerung Ø 16 mm mit Korn für Bohrspitzenhalter	
03702L-1	Zylindrischer Spiralbohrer Ø 4.5 mm	
03702L-2	Verlängerung + Spitze Ø 8 - Ø 4.5 mm	
03702L-3	Gewindezapfen 12-28	
03703L-1	Verlängerung + Spitze Ø 7 - Ø 4.5 mm	
03702L-4	Gewindeeinsatz 12-28	
03702L-5	Gewindezapfen M9x1	
03707L-7	Gewindezapfen 1/4" - 28	
03707L-9	Gewindeeinsatz 1/4"	
03705L-3	Gewindezapfen M8x1	

Die Zündkerze muss hohen Temperaturen, erhöhtem Druck, Schwingungen und korrosiver Angriffe widerstehen, die sich während der Verbrennung entwickeln.

Die Spitze der Zündkerze muss sehr präzise positioniert sein, um den Kraftstoff zu entzünden. Sie darf nicht zu tief in die Verbrennungskammer eindringen, da dies zu einer unkorrekten Verbrennungszündung führen könnte. Aus diesen Gründen ist der Austausch problematisch und die Zündkerzen können leicht in ihrem Sitz zerbrechen.

- Einsatzvorgaben:  
Quote A  $\geq$  14 mm (M10)  
Quote A  $\geq$  20 mm (M9, M8)  
Quote L  $\leq$  13 mm  
· L (Gewinde)

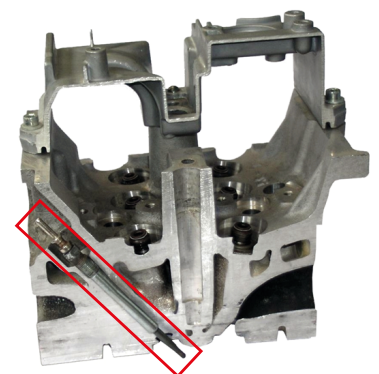
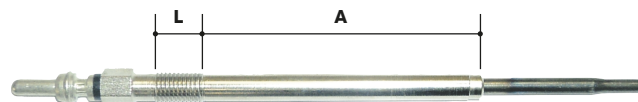

**DER EINSATZ VON DIESER AUSTRÜSTUNG VERLANGT BESONDERE AUFMERKSAMKEIT UND SORGFALT BEI DER POSITIONIERUNG AUF DER ZÜNDKERZENACHSE, UM PROBLEME AUF DEM ZYLINDERKOPF ZU VERMEIDEN UND KEINEN BRUCH DER WERKZEUGE ZU RISKIEREN; ALS BEZUG KANN DIE NEIGUNG DER ANLIEGENDEN ZÜNDKERZE VERWENDET WERDEN (KLEINE UNTERSCHIEDE:  $\pm$  5° SIND FÜR DAS ERGEBNIS UNBEDEUTEND).**

**WICHTIG** - Beim Bohren mit Bohrer mit zwei Durchmessern (für die Beseitigung des geschnittenen Oberteils der kleinen Kerze), um die Qualität des Bohrers zu bewahren und seine Dauer zu steigern, strikt die folgende Noten folgen:

1) MAX Drehzahl: 200 Umdrehungen/Min

2) Nach wenigen mm von Bohrungstiefe (1-3 mm), den Bohrer wegnehmen und mit Kühlschmiermittel abschmieren, den Sitz der kleinen Kerze blasen, um die Metallspäne zu beseitigen.

Die Bohrung durchführen bis der totalen Beseitigung des geschnittenen Teils der kleinen Kerze.

## VERFAHREN:

Alle nachfolgend aufgeführten Phasen müssen mit höchster Sorgfalt, Präzision und Aufmerksamkeit ausgeführt werden.

- Mit Hilfe der geeigneten Abzugsbuchse (der drei zur Auswahl stehenden Durchmesser  $\varnothing 2,5$  -  $\varnothing 3,5$  -  $\varnothing 4$ ) den Endteil der Zündkerzenelektrode entfernen (Abb. 1).

Bezugscode: 03700L-1, 03700L-2, 03700L-3

Notwendige Werkzeuge: Schlüssel  $\square$  3/8"

- Falls das Mittelteil der Elektrode stecken bleiben sollte, das Führungsröhrchen nehmen (es stehen zwei Innendurchmesser zur Verfügung:  $\varnothing 2,7$  -  $\varnothing 3,6$ ) und dieses auf das verbliebene Elektrodenteil einsetzen (Abb. 3).

Bezugscode: 03700L-4, 03700L-5

- Die Verlängerung und geeignete Spitze (es stehen die beiden Durchmesser  $\varnothing 2,7$  bzw.  $\varnothing 3,6$  zur Verfügung) verwenden, um den verbliebenen Elektrodenteil zu entfernen (Abb. 3).

Bezugscode: 03700L-6, 03700L-7

Notwendige Werkzeuge: Elektrischer/pneumatischer Bohrer

- Die Vorbohrung für den Abzug der Zündkerze (Abb.4) mit Hilfe der im Kit enthaltenen zylindrischen Bohrspitze ausführen (Länge  $\varnothing 5,5$  M10, Länge  $\varnothing 4,5$  M9, M8).

Bezugscode: 03700L-8, 03702L-1

Notwendige Werkzeuge: Elektrischer/pneumatischer Bohrer

- Mit Hilfe der Verlängerung und der Spitze mit 2 Durchmessern die Bohrung ausführen, dabei darauf achten in kleinen Schritten (1÷2 mm) vorzugehen und die Metallspäne wegblasen, bis die Spitze den Anschlag erreicht und vollständig den Gewindeteil der Zündkerze entfernt hat. Auf diese Weise haben Sie den oberen Teil der Zündkerze entfernt (Abb. 5).

Bezugscode: 03700L-9 (+03700L-10), 03702L-2, 03703L-1

Notwendige Werkzeuge: Elektrischer/pneumatischer Bohrer

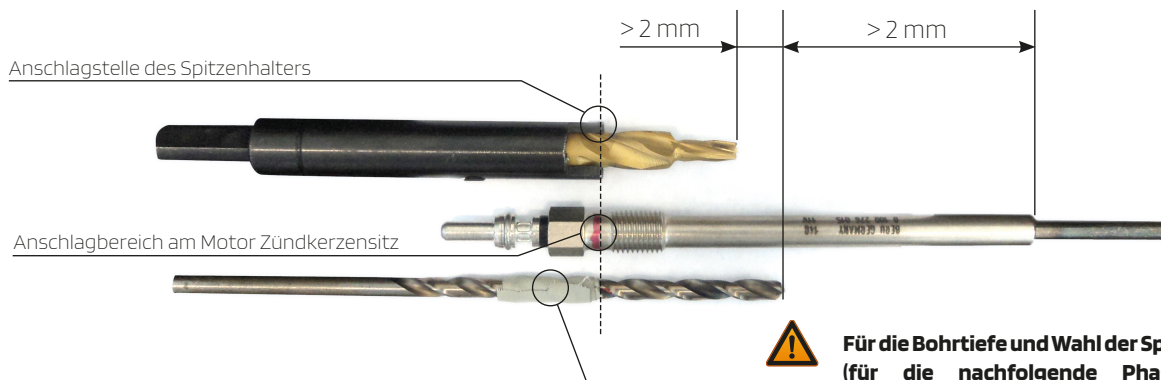
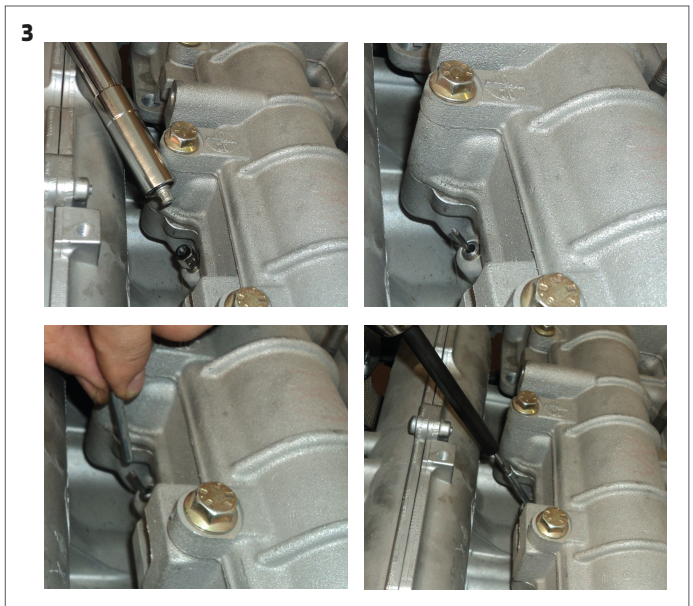
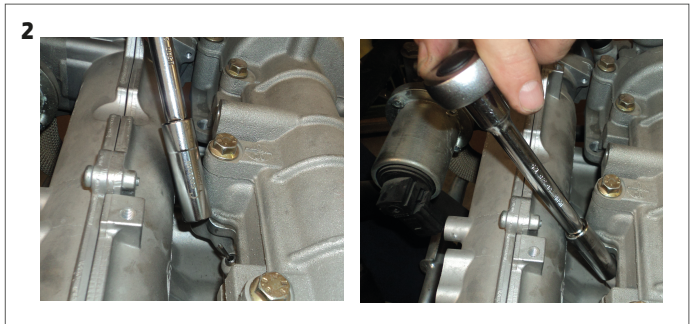
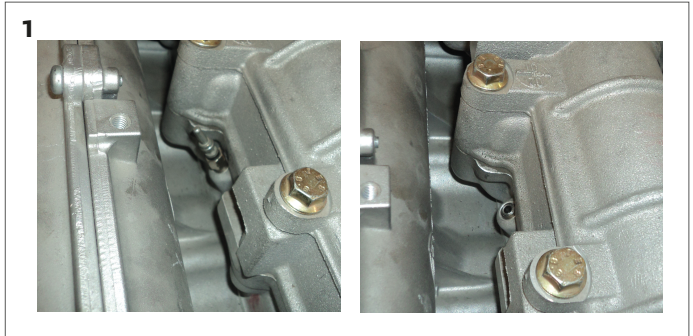

Für die Bohrtiefe und Wahl der Spitze mit 2 Durchmessern (für die nachfolgende Phase) das nachfolgend aufgeführten Schema befolgen. Für den Erhalt eines Grenzpunktes für die Bohrtiefe wird die Verwendung von Klebeband empfohlen.



**Falls notwendig (Raumbedarf des Motors) die Verlängerung für den Spitzenhalter Code 03700L-17 verwenden.**

- Mit Hilfe des Gewindepapfen  $\frac{1}{4}$ -28 UNF (M10) oder 12-28 UNF (M9, M8) + Verlängerung die manuelle Gewindebohrung für den Abzug der Zündkerze (Abb. 6) ausführen.

Bezugscode: 03707L-7, 03702L-3

Notwendige Werkzeuge: Sperradschlüssel

- Für die Erneuerung des Gewindes für den Einsatz der neuen Zündkerze, den im Kit enthaltenen Gewindepapfen + Verlängerung verwenden (Abb. 7):
  - M10x1                      · M9x1
  - M10x1,25                · M8x1

Bezugscode: 03700L-13, 03700L-14, 03702L-5, 03705L-3

Notwendige Werkzeuge: Sperradschlüssel



**Nach der Erneuerung des Gewindes für die neue Zündkerze, den Sitz mit Druckluft reinigen, um Schmutz- und Materialreste zu entfernen.**

- Nach Ausführung des Gewindes für die neue Zündkerze, den Gewindeeinsatz  $\frac{1}{4}$ -28 UNF (M10) oder 12-28 UNF (M9, M8) für den Abzug am Stift mit der Gewindebohrung M8 (mit montiertem Schlagwerkhammer) (Abb. 8) einsetzen.

Bezugscode: 03707L-9, 03700L-12, 03700L-11, 03702L-4

Notwendige Werkzeuge: Kombischlüssel CH-8;  
Sechskantschlüssel CH-6



**Falls notwendig (Raumbedarf des Motors) die Verlängerung für den Abzugsstift Code 03700L-16 verwenden.**

- Den Gewindeeinsatz für den Abzug der Kerze festschrauben und mit der Abzugsphase durch Einwirken auf den Schlagwerkhammer fortfahren (Abb. 8 Ref. A)
- Mit dem Einsetzen der neuen Zündkerze fortfahren (Abb. 9)

4

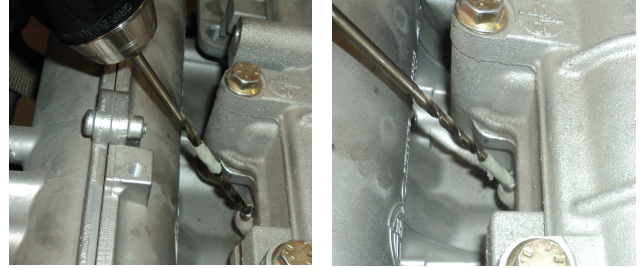

5



6



7



8

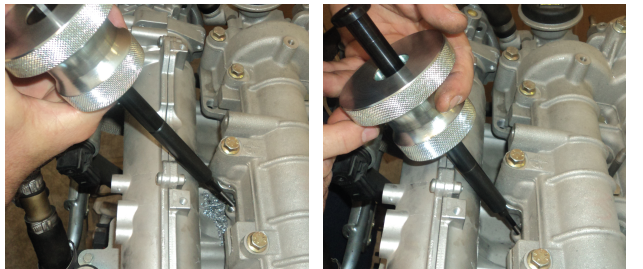







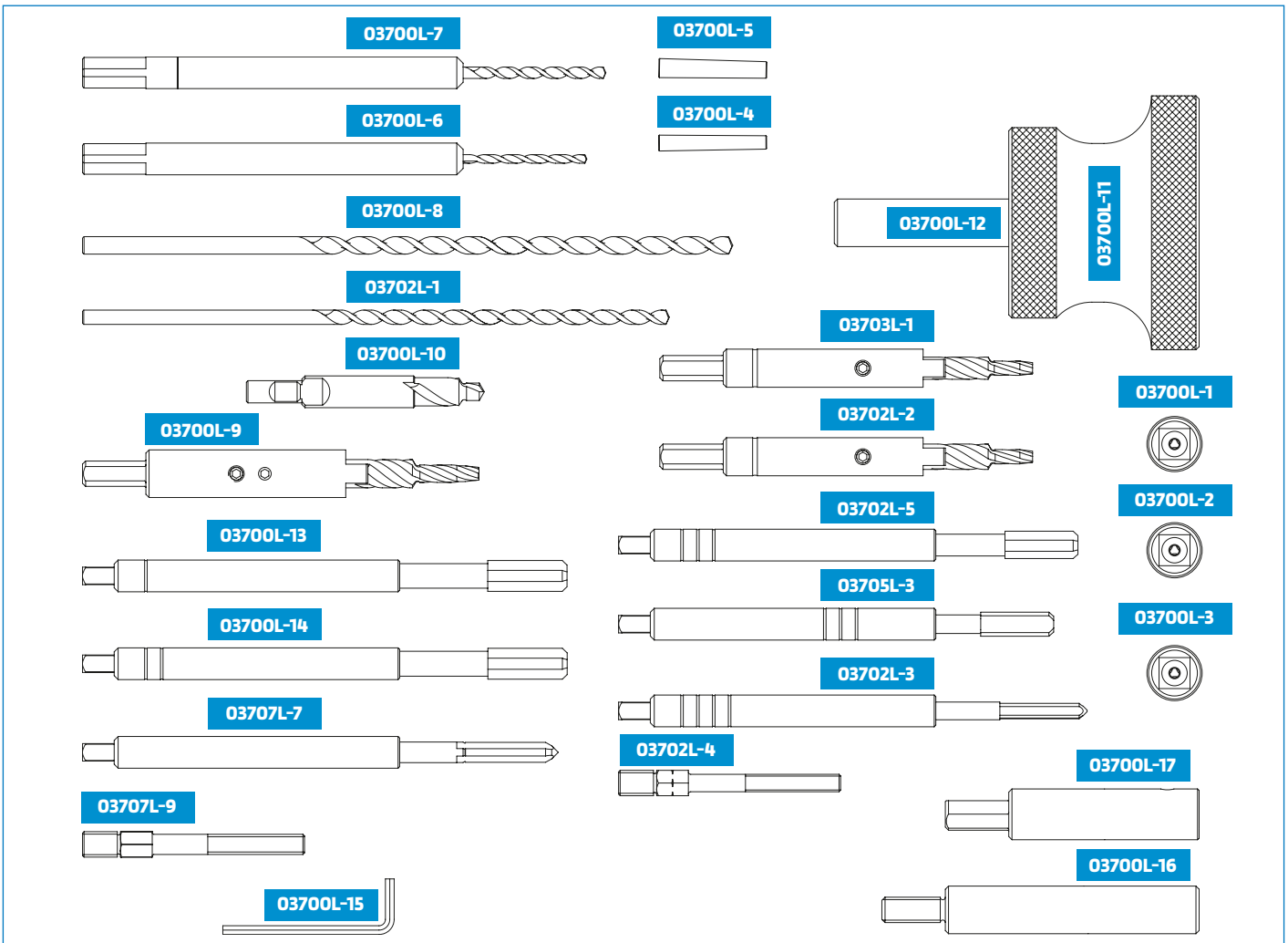



















9



## COMPONENTS



Ref.	Description	
03700L-1	Ø 2.5 mm socket	
03700L-2	Ø 3.5 mm socket	
03700L-3	Ø 4 mm socket	
03700L-4	Ø 2.7 mm drilling guide	
03700L-5	Ø 3.6 mm drilling guide	
03700L-6	Extension + Ø 2.7 mm drill bit	
03700L-7	Extension + Ø 3.6 mm drill bit	
03700L-8	Twist drill bit Ø 5.5 mm	
03700L-9	Extension + Ø 8.9 - Ø 5.5 mm drill bit	
03700L-10	Short double diameters drill bit: Ø 8.9 - 5.5	

Ref.	Description	
03700L-11	Hammer	
03700L-12	M8 pin	
03700L-13	M10x1 male	 M10x1
03700L-14	M10x1.25 male	 M10x1.25
03700L-15	2.5 mm allen key	
03700L-16	Ø 15 mm extension for extraction pin	
03700L-17	Ø 16 mm extension	
03702L-1	Twist drill bit Ø 4.5 mm	
03702L-2	Extension + Ø 8 - Ø 4.5 mm drill bit	 M9
03702L-3	12-28 male	 (M8) 12-28 UNF
03703L-1	Extension + Ø 7 - Ø 4.5 mm drill bit	 M8
03702L-4	12-28 threaded insert	
03702L-5	M9x1 male	 M9x1
03707L-7	1/4" - 28 male	 (M10) 1/4-28 UNF
03707L-9	1/4" threaded insert	 (M10) 1/4-28 UNF
03705L-3	M8x1 male	 M8x1

The glow plug must be able to withstand high temperatures, high pressures, vibrations and attack of corrosive agents which develop during the combustion.

The tip of the glow plug must be positioned very precisely to ignite the fuel.

In fact it should not penetrate too deeply into the combustion chamber as it may trigger the combustion incorrectly. For these reasons, the replacement is problematic and the glow plugs easily break in their seat.

- Specifications for use:
  - Dimension A  $\geq$  14 mm (M10)
  - Dimension A  $\geq$  20 mm (M9, M8)
  - Dimension L  $\leq$  13 mm
  - L (thread)

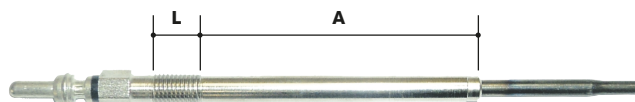

**THE USE OF THIS EQUIPMENT REQUIRES ATTENTION AND CARE IN POSITIONING ON THE AXIS OF THE GLOW PLUG TO AVOID PROBLEMS ON THE HEAD AND TO AVOID THE RISK OF BREAKING THE TOOLS; IT CAN BE HELPFUL TO USE AS REFERENCE THE INCLINATION OF ADJACENT GLOW PLUG (SMALL DIFFERENCES:  $\pm 5^\circ$  ARE NOT SIGNIFICANT FOR THE FINAL RESULT).**

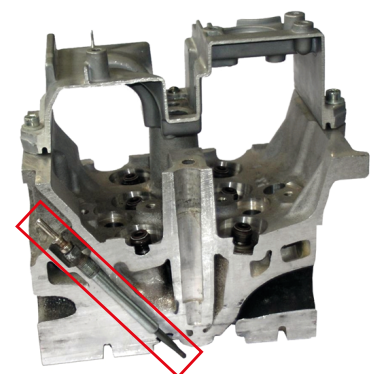

**IMPORTANT** - During the drilling phase with two-diameter drill (for the removal of the upper threaded part of the glow plug), to preserve the quality of the drill and increase its duration, follow absolutely these notes:

1) MAX number of revolutions: 200 revolutions/min

2) After a few mm of drilling depth (1-3 mm), remove the drill and lubricate with cutting fluid, blow the seat of the glow plug to remove the metal shavings. Carry on the drilling phase in this way till the complete removal of the threaded part of the glow plug.

## PROCEDURE:

All of the following steps must be performed with the utmost care, precision and attention

- Use the "roller" extractor suitable (among the three supplied  $\varnothing 2.5 - \varnothing 3.5 - \varnothing 4$ ) to remove the terminal part of the electrode of the spark plug (fig. 1).

Reference codes: 03700L-1, 03700L-2, 03700L-3

Tools required: Wrench  $\square 3/8$  "

- If necessary, in the case part of the central electrode should remain, take the conical driving sheath (among the two provided with inner hole  $\varnothing 2.7 - \varnothing 3.6$ ) and put it on the remained part of electrode (fig. 3).

Reference codes: 03700L-4, 03700L-5

- Use the extension + bit suitable (among the two supplied with tip  $\varnothing 2.7$  or  $\varnothing 3.6$ ) to remove the portion of the electrode remained (fig. 3).

Reference codes: 03700L-6, 03700L-7

Tools required: Electric/pneumatic drill

- Make the pilot hole for the extraction of the glow plug (fig. 4) using the long cylindrical spiral bit  $\varnothing 5,5$  (M10) or  $\varnothing 4,5$  (M9, M8) included in the kit.

Reference codes: 03700L-8, 03702L-1

Tools required: Electric/pneumatic drill

- Use the extension + bit with 2 diameters and begin the drilling operation, taking care to drill in small sections (1 to 2 mm) and blow to remove the metal shavings, until the bit reaches the stop shoulder and removes completely the threaded part of the glow plug.

In this way you have removed the upper part of the glow plug (fig. 5).

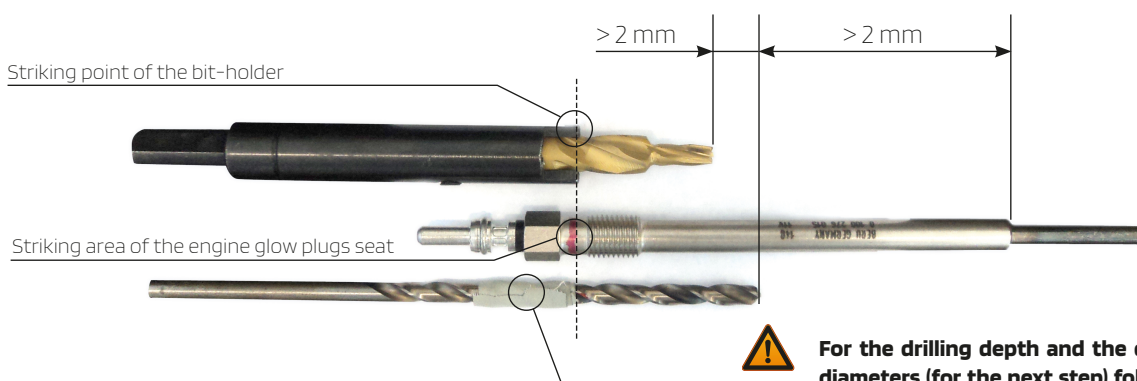
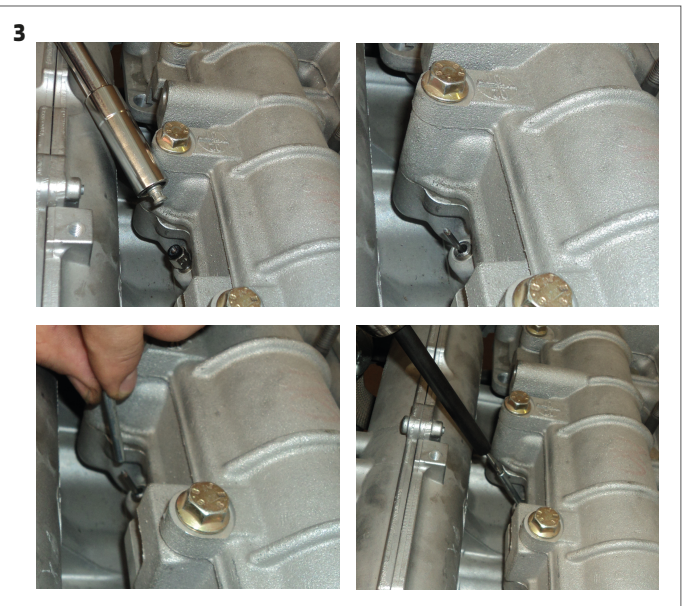
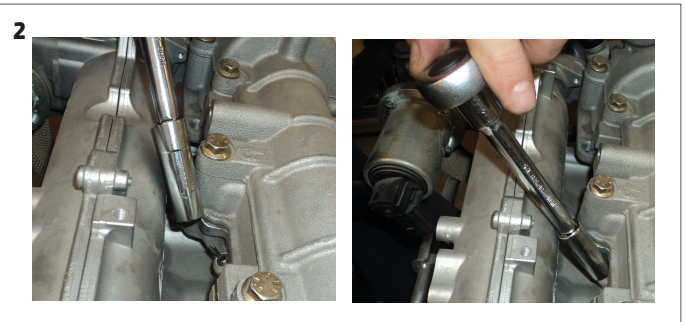
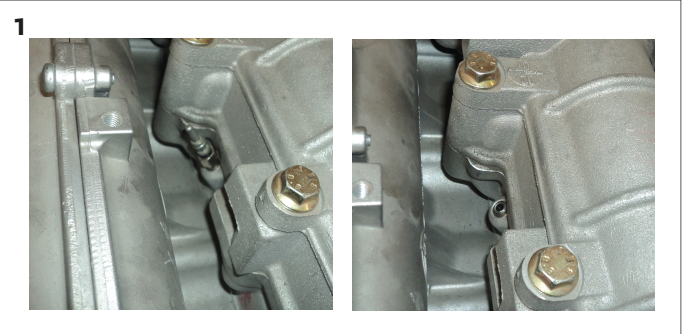

**For the drilling depth and the choice of the bit with 2 diameters (for the next step) follow the diagram below. To have a limit point of reference for the drilling depth, we recommend the use of adhesive tape.**



Reference codes: 03700L-9 (+03700L-10), 03702L-2, 03703L-1

Tools required: Electric/pneumatic drill

**⚠ If necessary (engine size) use the extension for bit-holder code 03700L-17.**

- Use the ¼ -28 UNF male (M10) or 12-28 UNF male (M9, M8) + extension and start the manual threading operation for removing the spark plug (fig. 6)

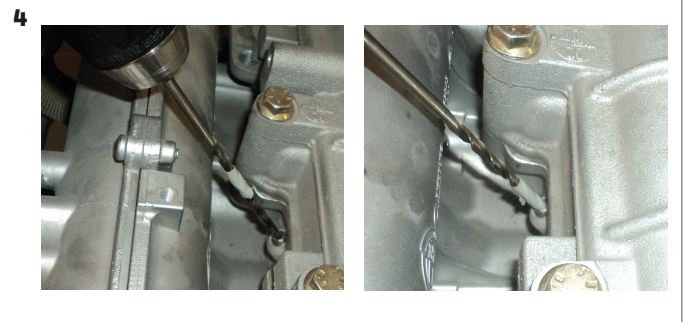

Reference codes: 03707L-7, 03702L-3

Tools required: Ratchet wrench

- To renew the thread for the new glow plug which will be mounted, use the included male + extension (fig. 7)
- M10x1                      · M9x1
- M10x1,25                · M8x1

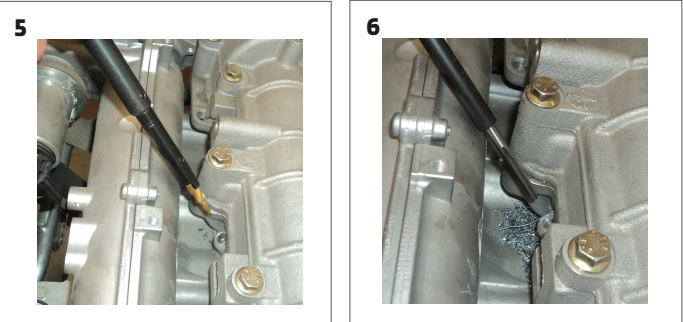

Codici di riferimento: 03700L-13, 03700L-14, 03702L-5, 03705L-3

Tools required: Ratchet wrench

**⚠ Once renewed the thread for the new spark plug, clean the seat with compressed air to remove dirt and / or material debris.**

- Once the thread for the new spark plug is ready, tighten the threaded insert ¼ -28 UNF (M10) or 12-28 UNF (M9, M8) for extraction to the pin with threaded hole M8 (with the impact mass mounted) (fig. 8)



Reference codes: 03707L-9, 03700L-12, 03700L-11, 03702L-4

Tools required: Combination wrench CH-8;  
Hexagonal wrench CH-6





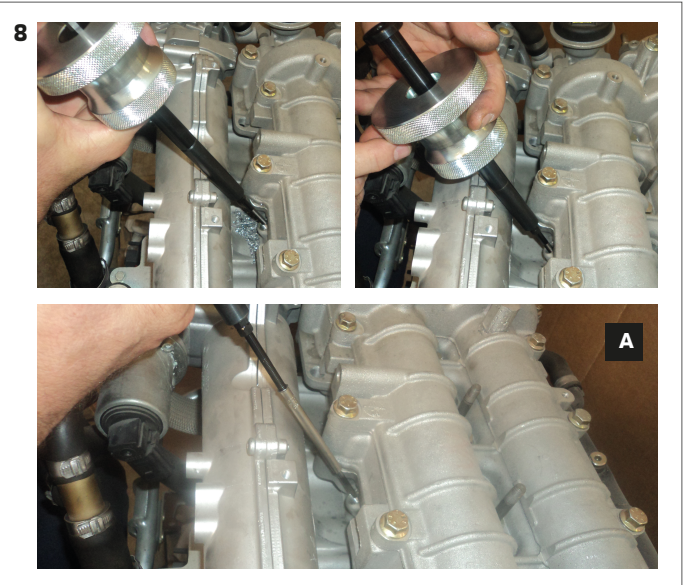



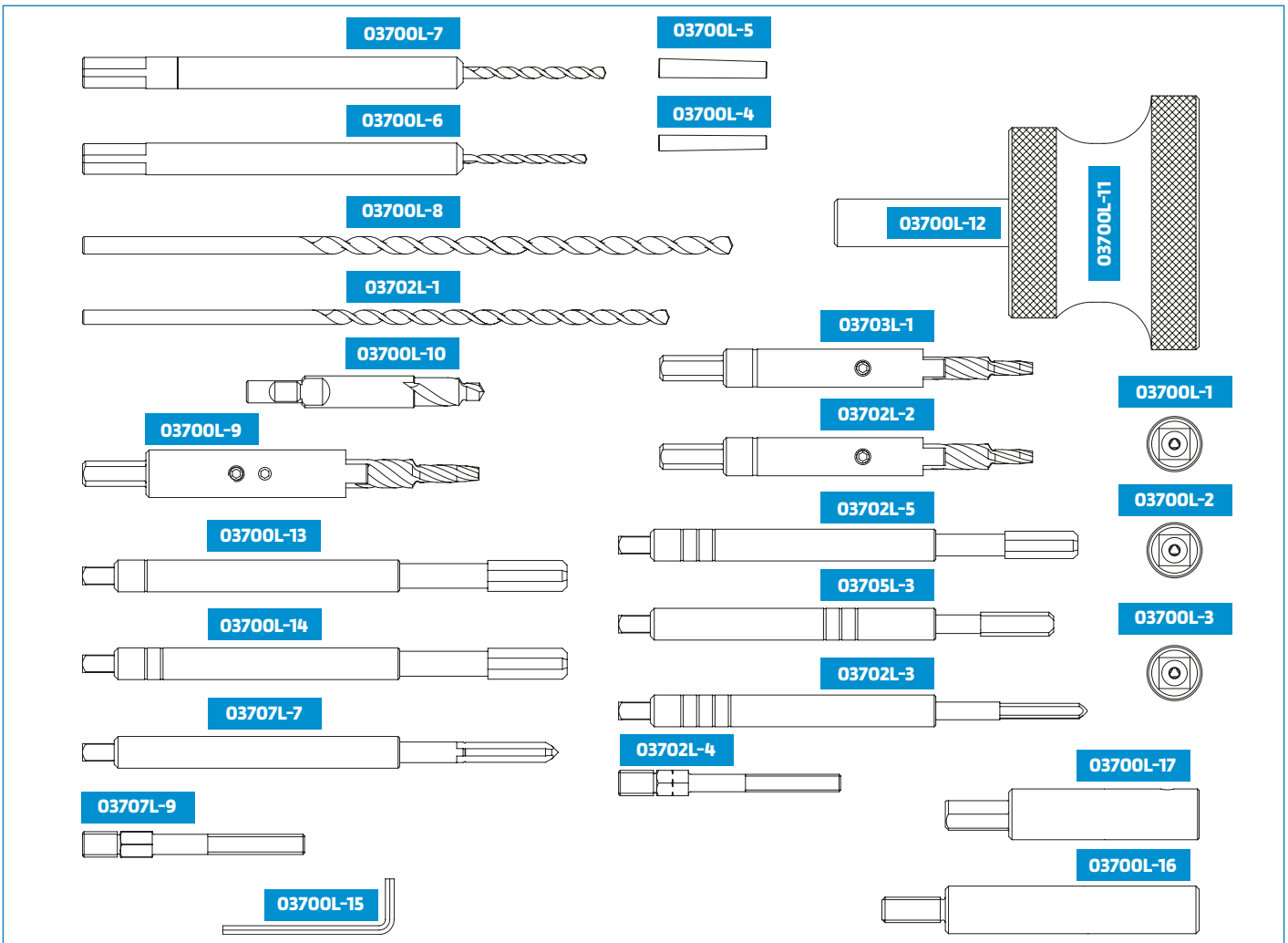

**⚠ If necessary (engine size) use the extension for extraction pin code 03700L-16.**















- Screw the threaded insert for extraction to the glow plug and proceed with the extraction phase acting on the impact mass (fig. 8 ref. A)
- Continue inserting the new glow plug (fig. 9)



## COMPOSANTS

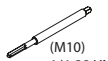
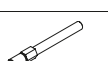

Réf.	Description	
03700L-1	Douille d'extraction à rouleaux Ø 2,5 mm	 Ø 2,5
03700L-2	Douille d'extraction à rouleaux Ø 3,5 mm	 Ø 3,5
03700L-3	Douille d'extraction à rouleaux Ø 4 mm	 Ø 4
03700L-4	Tube de guidage pour perçage Ø 2,7 mm	 Ø 2,7
03700L-5	Tube de guidage pour perçage Ø 3,6 mm	 Ø 3,6
03700L-6	Rallonge + foret Ø 2,7 mm	 Ø 2,7
03700L-7	Rallonge + foret Ø 3,6 mm	 Ø 3,6
03700L-8	Foret hélicoïdal cylindrique Ø 5,5 mm	
03700L-9	Rallonge + foret Ø 8,9 - Ø 5,5 mm	 M10
03700L-10	Foret deux diamètres Ø 8,9 - Ø 5,5 mm court	 M10

Réf.	Description	
03700L-11	Masse battante	
03700L-12	Tige M8 pour batteur	
03700L-13	Taraud M10x1	
03700L-14	Taraud M10x1,25	
03700L-15	Clé mâle 6 pans 2,5 mm	
03700L-16	Rallonge Ø 15 mm pour tige d'extraction	
03700L-17	Rallonge Ø 16 mm avec vis sans tête pour porte-foret	
03702L-1	Foret hélicoïdal cylindrique Ø 4.5 mm	
03702L-2	Rallonge + foret Ø 8 - Ø 4.5 mm	
03702L-3	Taraud 12-28	
03703L-1	Extension + Ø 7 - Ø 4.5 mm drill bit	
03702L-4	Embout fileté 12-28	
03702L-5	Taraud M9x1	
03707L-7	Taraud 1/4" - 28	
03707L-9	Embout fileté 1/4"	
03705L-3	Taraud M8x1	

La bougie est prévue pour résister aux hautes températures, aux pressions élevées, aux vibrations et à l'agression des agents corrosifs qui se produisent pendant la combustion.

La pointe des bougies doit être positionnée de façon bien précise afin d'enflammer le carburant. Elle ne doit pas pénétrer trop profondément dans la chambre de combustion car elle pourrait amorcer la combustion de façon incorrecte.

Le remplacement des bougies est de ce fait difficile et il arrive fréquemment que les bougies se cassent dans leur emplacement.

- Spécifications d'utilisation:
- Cote A  $\geq$  14 mm (M10)
- Cote A  $\geq$  20 mm (M9, M8)
- Cote L  $\leq$  13 mm
- L (filetage)

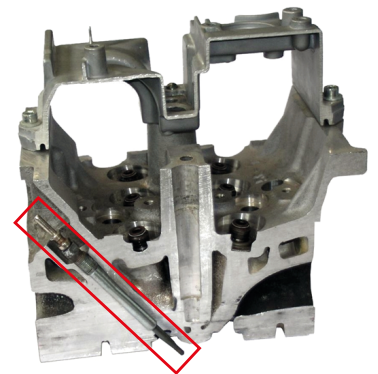
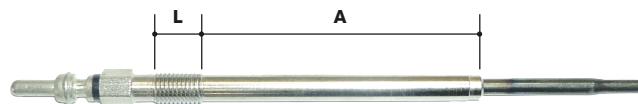

**⚠ L'UTILISATION DE CET EQUIPEMENT NECESSITE LE MAXIMUM D'ATTENTION LORS DU POSITIONNEMENT SUR L'AXE DE LA BOUGIE AFIN D'EVITER D'ENDOMMAGER LA CULASSE ET DE PROVOQUER LA RUPTURE D'OUTILS; IL EST POSSIBLE DE PRENDRE POUR REFERENCE L'INCLINAISON DE LA BOUGIE ADJACENTE (DE PETITES DIFFERENCES DE  $\pm 5^\circ$  SONT SANS IMPORTANCE POUR LE RESULTAT FINAL).**

**IMPORTANT** – Pendant le perçage avec le foret à deux diamètres (pour enlever la partie supérieure filetée de la bougie), pour préserver la qualité du foret et augmenter sa durée, suivre absolument ces indications :

1) Nombre de tours MAX de travail : 200 tours/min

2) Après quelques mm de profondeur de perçage (1÷3 mm), décharger le foret et le lubrifier avec de l'huile de coupe, souffler dans le logement de la bougie pour enlever les copeaux de métal.

Continuer la phase de perçage jusqu'à enlever complètement la partie filetée de la bougie.

## PROCÉDURE:

Toutes les phases indiquées ci-après doivent être accomplies avec le maximum de soin, de précision et d'attention.

- Utiliser la douille d'extraction à rouleaux appropriée (à choisir parmi les trois fournies Ø 2,5 - 3,5 - 4) pour enlever l'extrémité de l'électrode de la bougie (fig. 1).

Codes de référence: 03700L-1, 03700L-2, 03700L-3

Outils nécessaires: Clé □ 3/8"

- Si cela est nécessaire, au cas où une partie de l'électrode centrale reste encastrée, prendre le tube de guidage conique (à choisir parmi les deux fournis avec trou intérieur Ø 2,7 - 3,6) et l'enfiler sur la partie d'électrode qui est restée bloquée (fig. 3).

Codes de référence: 03700L-4, 03700L-5

- Utiliser la rallonge + le foret approprié (à choisir parmi les deux fournies avec foret Ø 2,7 ou Ø 3,6) pour enlever la partie d'électrode qui est restée bloquée (fig. 3).

Codes de référence: 03700L-6, 03700L-7

Outils nécessaires: Perceuse électrique/pneumatique

- Effectuer le pré-trou pour l'extraction de la bougie (fig. 4) à l'aide du foret hélicoïdal cylindrique long de Ø5,5 (M10) ou Ø4,5 (M9, M8) présent dans le kit.

Codes de référence: 03700L-8, 03702L-1

Outils nécessaires: Perceuse électrique/pneumatique

- Utiliser la rallonge + la pointe à 2 diamètres et commencer l'opération de perçage, en procédant par paliers de 1÷2 mm, tout en soufflant pour éliminer les copeaux métalliques, jusqu'à ce que le foret ait touché le fond et complètement enlevé le filetage de la bougie. Cette opération permet d'enlever la partie supérieure de la bougie (fig. 5).

Codes de référence: 03700L-9 (+03700L-10), 03702L-2, 03703L-1

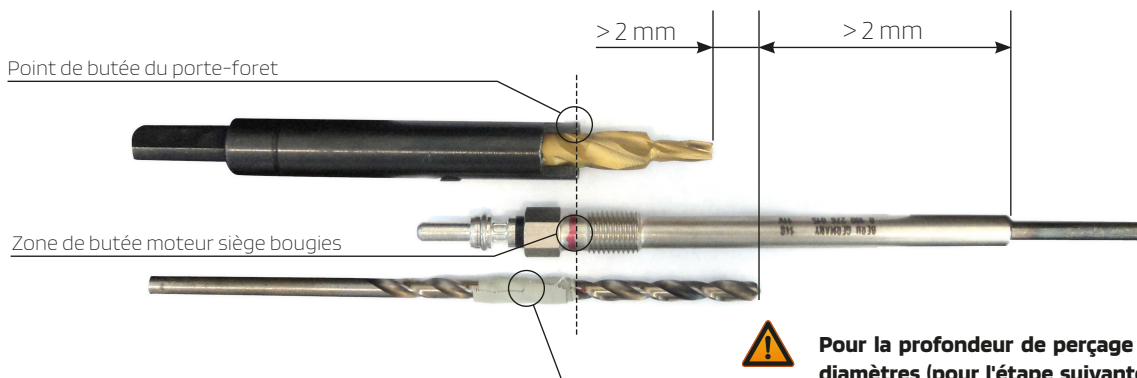
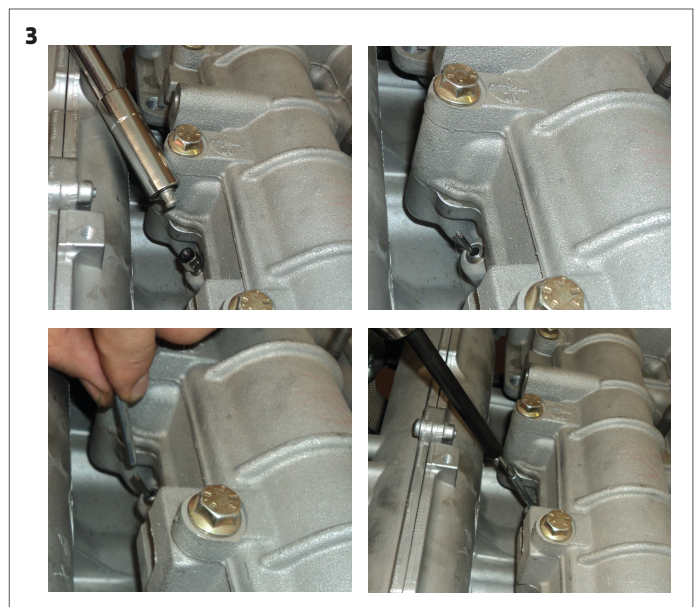
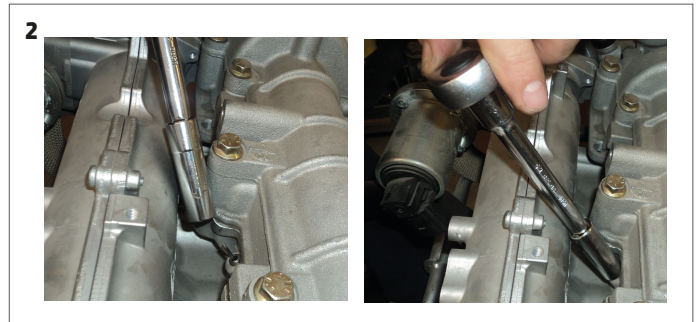
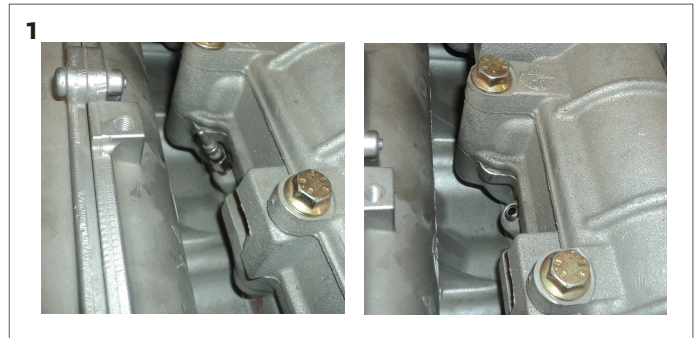

**Pour la profondeur de perçage et le choix du foret à 2 diamètres (pour l'étape suivante), se référer au schéma ci-après. Pour avoir un point limite de référence pour la profondeur de perçage, il est recommandé d'utiliser un ruban adhésif.**

Outils nécessaires: Perceuse électrique/pneumatique

**⚠ Si cela est nécessaire (voir dimensions du moteur), utiliser la rallonge porte-foret référence 03700L-17.**

- Utiliser le taraud  $\frac{1}{4}$  -28 UNF (M10) ou 12-28 UNF (M9, M8) + rallonge et commencer l'opération de filetage manuel pour l'extraction de la bougie (fig. 6).

Codes de référence: 03707L-7, 03702L-3

Outils nécessaires: Clé à cliquet

- Pour refaire le filetage pour la nouvelle bougie à installer, utiliser le taraud + la rallonge fournis (fig. 7):
  - M10x1                      · M9x1
  - M10x1,25                · M8x1

Codes de référence: 03700L-13, 03700L-14, 03702L-5, 03705L-3

Outils nécessaires: Clé à cliquet

**⚠ Après avoir refait le filetage pour la nouvelle bougie, nettoyer le logement avec de l'air comprimé afin d'éliminer les saletés et/ou les résidus de matériau.**

- Le filetage de la nouvelle bougie effectué, visser l'embout fileté  $\frac{1}{4}$  -28 UNF (M10) ou 12-28 UNF (M9, M8) pour l'extraction à la tige à trou fileté M8 (avec la masse battante installée) (fig. 8).

Codes de référence: 03707L-9, 03700L-12, 03700L-11, 03702L-4

Outils nécessaires: Clé mixte n°8;  
Clé mâle 6 pans n°6

**⚠ Si cela est nécessaire (voir dimensions du moteur), utiliser la rallonge pour tige d'extraction référence 03700L-16.**



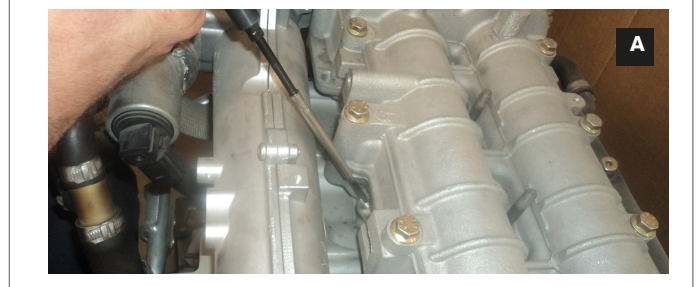
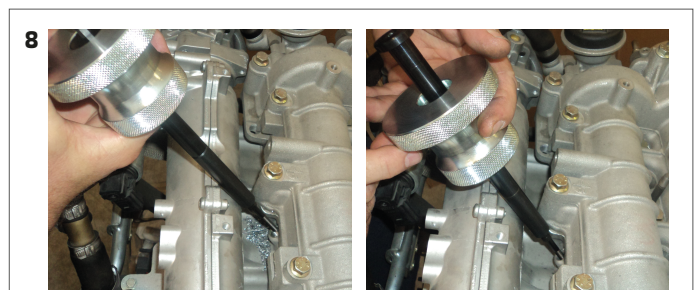
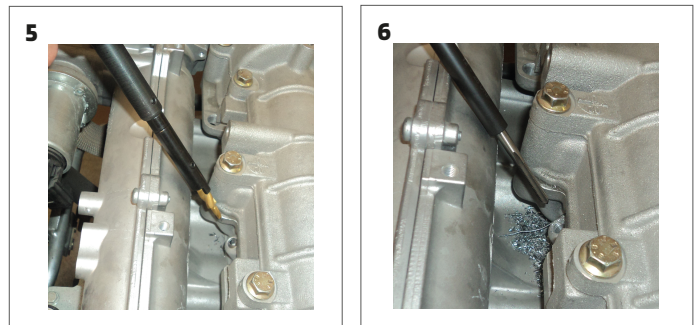
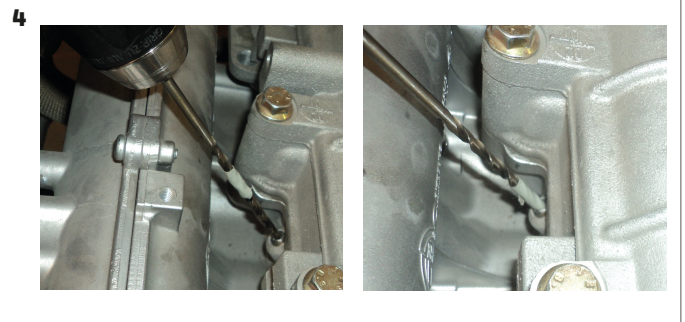



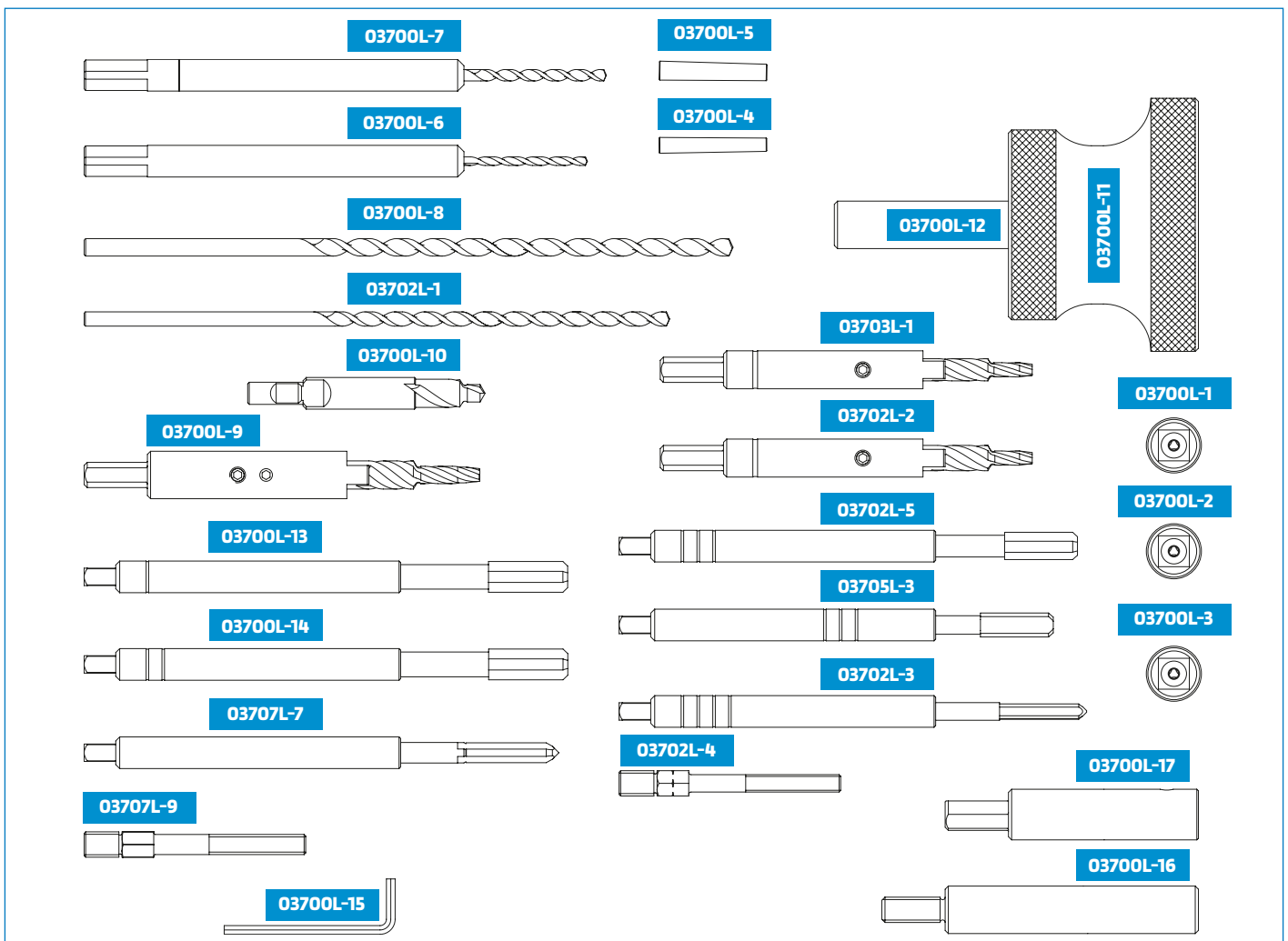







- Visser l'embout fileté pour l'extraction à la bougie puis procéder avec l'opération d'extraction en agissant sur la masse battante (fig. 8, ref. A)
- Introduire la bougie neuve (fig. 9)



## COMPONENTI

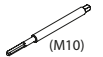
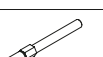

Rif.	Descrizione	
03700L-1	Bussola di estrazione a rulli Ø 2.5 mm	 Ø 2.5
03700L-2	Bussola di estrazione a rulli Ø 3.5 mm	 Ø 3.5
03700L-3	Bussola di estrazione a rulli Ø 4 mm	 Ø 4
03700L-4	Tubino di guida per foratura Ø 2.7 mm	 Ø 2.7
03700L-5	Tubino di guida per foratura Ø 3.6 mm	 Ø 3.6
03700L-6	Prolunga + punta Ø 2.7 mm	 Ø 2.7
03700L-7	Prolunga + punta Ø 3.6 mm	 Ø 3.6
03700L-8	Punta elicoidale cilindrica Ø 5.5 mm	
03700L-9	Prolunga + punta Ø 8.9 - Ø 5.5 mm	 M10
03700L-10	Punta due diametri Ø 8.9 - Ø 5.5 mm corta	 M10

Rif.	Descrizione	
03700L-11	Massa battente	
03700L-12	Perno M8 per battitoio	
03700L-13	Maschio M10x1	
03700L-14	Maschio M10x1.25	
03700L-15	Chiave a brugola 2.5 mm	
03700L-16	Prolunga Ø 15 mm per perno di estrazione	
03700L-17	Prolunga Ø 16 mm con grano per portapunta	
03702L-1	Punta elicoidale cilindrica Ø 4.5 mm	
03702L-2	Prolunga + punta Ø 8 - Ø 4.5 mm	
03702L-3	Maschio 12-28	
03703L-1	Prolunga + punta Ø 7 - Ø 4.5 mm	
03702L-4	Inserto filettato 12-28	
03702L-5	Maschio M9x1	
03707L-7	Maschio 1/4" - 28	
03707L-9	Inserto filettato 1/4"	
03705L-3	Maschio M8x1	

La candelella deve poter resistere ad alte temperature, elevate pressioni, vibrazioni e attacco di agenti corrosivi che si sviluppano durante la combustione. La punta della candelella deve essere posizionata molto precisamente per infiammare il carburante.

Non deve infatti penetrare troppo profondamente in camera di combustione in quanto potrebbe innescare la combustione non correttamente.

Per questi motivi la sostituzione è problematica e facilmente le candelelle si rompono nella propria sede.

- Specifiche di utilizzo:  
Quota A  $\geq$  14 mm (M10)  
Quota A  $\geq$  20 mm (M9, M8)  
Quota L  $\leq$  13 mm
- L (filettatura)

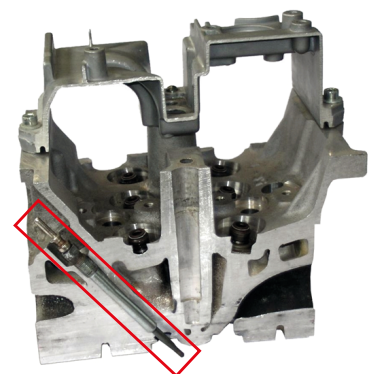
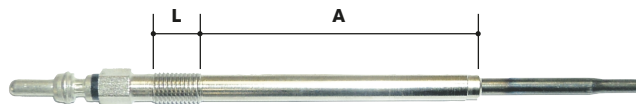

**! L'UTILIZZO DI QUESTA ATTREZZATURA ESIGE UN'ATTENZIONE ED UNA CURA NEL POSIZIONARSI SULL'ASSE DELLA CANDELETTA PER EVITARE PROBLEMI SULLA TESTATA E NON RISCHIARE LA ROTTURA DI UTENSILI; PUÒ AIUTARE TENERE COME RIFERIMENTO L'INCLINAZIONE DELLA CANDELETTA ADIACENTE (PICCOLE DIFFERENZE:  $\pm 5^\circ$  NON SONO SIGNIFICATIVE SUL RISULTATO FINALE).**

**IMPORTANTE** - In fase di foratura con la punta a due diametri (per rimuovere la parte superiore filettata della candelella), per preservare la qualità della punta e aumentare la sua durata, bisogna tassativamente attenersi alle seguenti note:

- 1) Numero di giri MAX di lavoro: 200 giri/min
- 2) Dopo pochi mm di profondità di foratura (1-3 mm), scaricare la punta e lubrificarla con olio da taglio, soffiare nella sede della candelella per togliere i trucioli metallici.

Proseguire la fase di foratura in questo modo fino alla completa rimozione della parte filettata della candelella.

## PROCEDURA:

Tutte le fasi riportate di seguito devono essere eseguite con la massima cura, precisione e attenzione

- Utilizzare la bussola di estrazione a rulli adatta (tra le tre in dotazione  $\varnothing 2,5 - \varnothing 3,5 - \varnothing 4$ ) per rimuovere la parte terminale dell'elettrodo della candele (fig. 1).

**Codici di riferimento:** 03700L-1, 03700L-2, 03700L-3

**Attrezzi richiesti:** Chiave  $\square 3/8''$

- Se necessario, nel caso dovesse rimanere parte dell'elettrodo centrale, prendere il tubino di guida conico (tra i due in dotazione con foro interno  $\varnothing 2,7 - \varnothing 3,6$ ) e infilarlo sulla parte di elettrodo rimasta (fig. 3).

**Codici di riferimento:** 03700L-4, 03700L-5

- Utilizzare la prolunga + punta adatta (tra le due in dotazione con punta  $\varnothing 2,7$  o  $\varnothing 3,6$ ) per rimuovere la parte di elettrodo rimasta (fig. 3).

**Codici di riferimento:** 03700L-6, 03700L-7

**Attrezzi richiesti:** Trapano elettrico / pneumatico

- Fare il preforo per l'estrazione della candele (fig. 4) utilizzando la punta elicoidale cilindrica lunga  $\varnothing 5,5$  (M10) o  $\varnothing 4,5$  (M9, M8) inclusa nel kit.

**Codici di riferimento:** 03700L-8, 03702L-1

**Attrezzi richiesti:** Trapano elettrico / pneumatico

- Utilizzare la prolunga + punta a 2 diametri e cominciare l'operazione di foratura, avendo cura di forare a piccoli tratti ( $1 \div 2$  mm) e soffiare per togliere i trucioli metallici, fino a che la punta raggiunga la battuta di arresto e abbia tolto completamente la parte filettata della candele. In questo modo avete rimosso la parte superiore della candele (fig. 5).

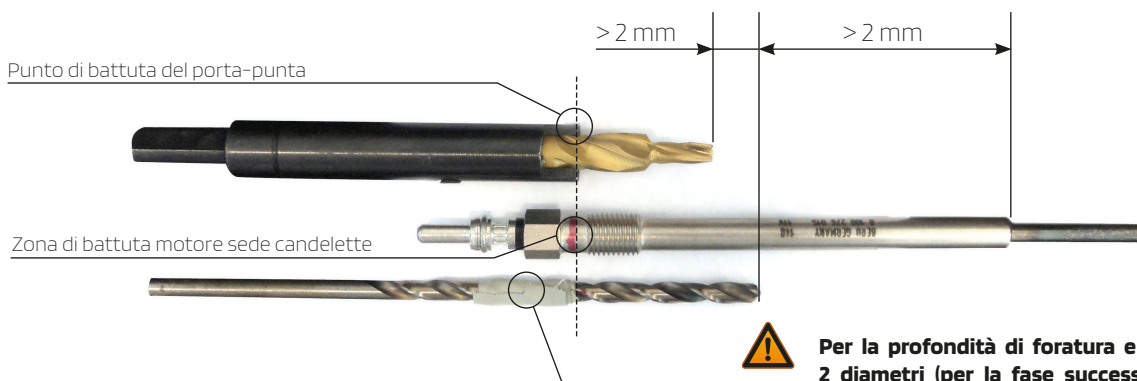
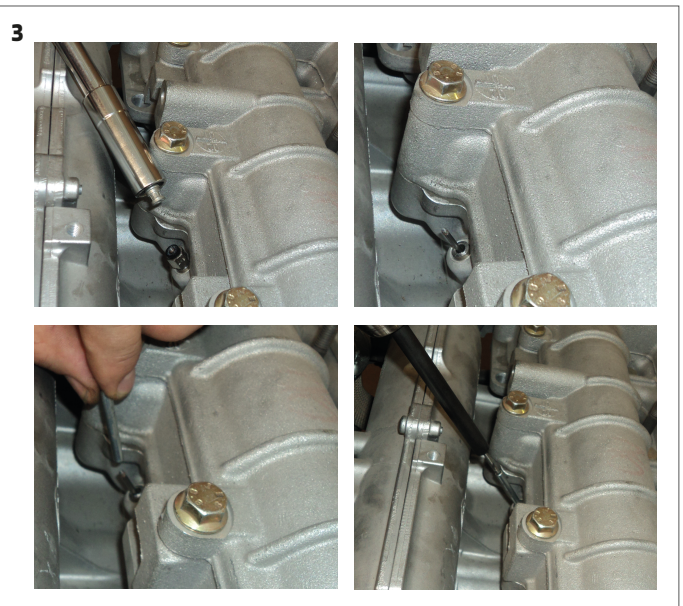
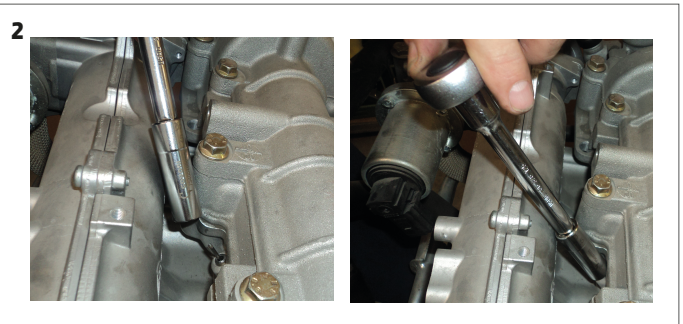
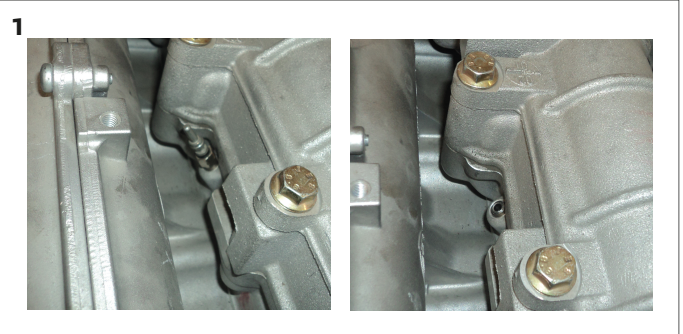

**Per la profondità di foratura e la scelta della punta a 2 diametri (per la fase successiva) seguire lo schema riportato di seguito. Per avere un punto limite di riferimento per la profondità di foratura, si consiglia l'utilizzo di nastro adesivo.**



Codici di riferimento: 03700L-9 (+03700L-10), 03702L-2, 03703L-1

Attrezzi richiesti: Trapano elettrico / pneumatico

**⚠ Se necessario (ingombro del motore) utilizzare la prolunga per portapunta codice 03700L-17.**

- Utilizzare il maschio  $\frac{1}{4}$ -28 UNF (M10) o 12-28 UNF (M9, M8) + prolunga e cominciare l'operazione di filettatura manuale per l'estrazione della candelecca (fig. 6)

Codici di riferimento: 03707L-7, 03702L-3

Attrezzi richiesti: Chiave a cricchetto

- Per rinnovare il filetto per la nuova candelecca che sarà montata, utilizzare il maschio + prolunga incluso (fig. 7):
  - M10x1
  - M9x1
  - M10x1,25
  - M8x1

Codici di riferimento: 03700L-13, 03700L-14, 03702L-5, 03705L-3

Attrezzi richiesti: Chiave a cricchetto

**⚠ Una volta rinnovato il filetto per la nuova candelecca, pulire la sede con aria compressa per eliminare sporco e/o residui di materiale.**

- Una volta ultimato il filetto per la nuova candelecca, avvitare l'inserto filettato  $\frac{1}{4}$ -28 UNF (M10) o 12-28 UNF (M9, M8) per l'estrazione al perno con foro filettato M8 (con la massa battente montata) (fig. 8)

Codici di riferimento: 03707L-9, 03700L-12, 03700L-11, 03702L-4

Attrezzi richiesti: Chiave combinata CH-8;  
Chiave esagonale CH-6





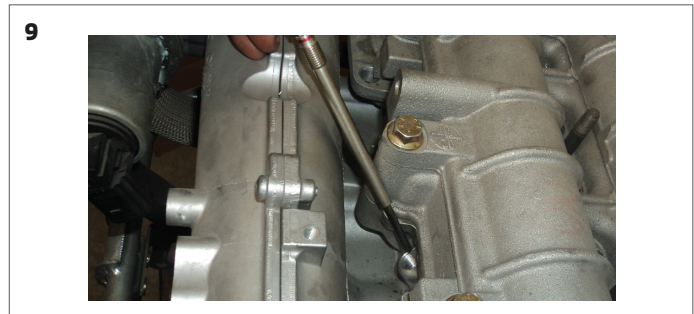
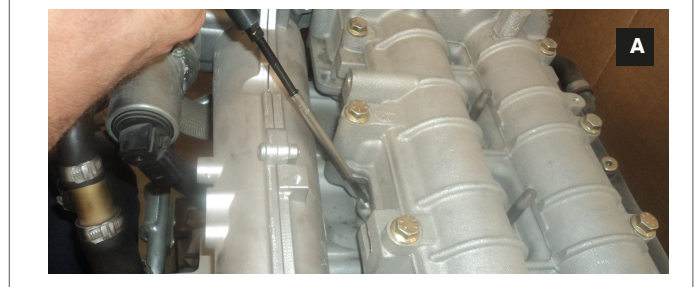
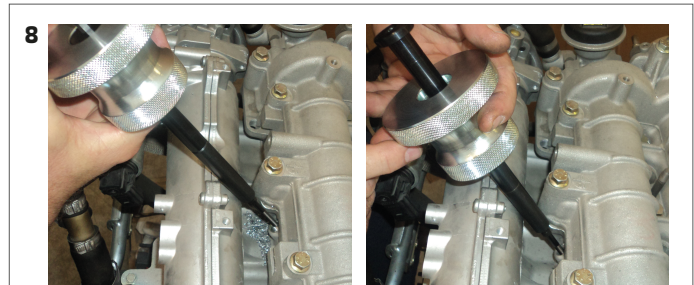
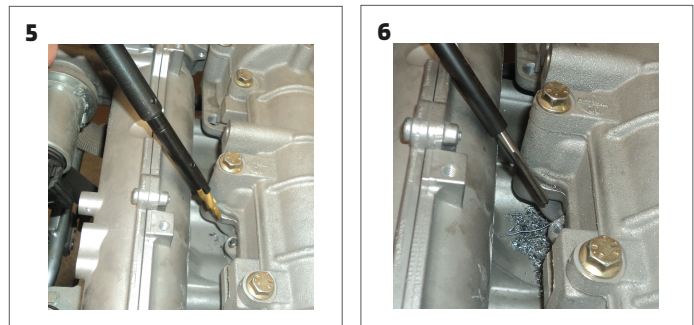
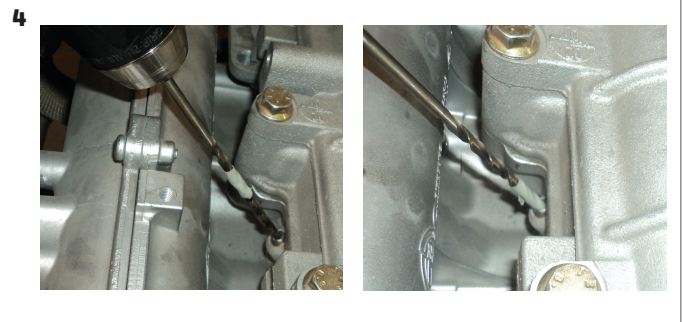



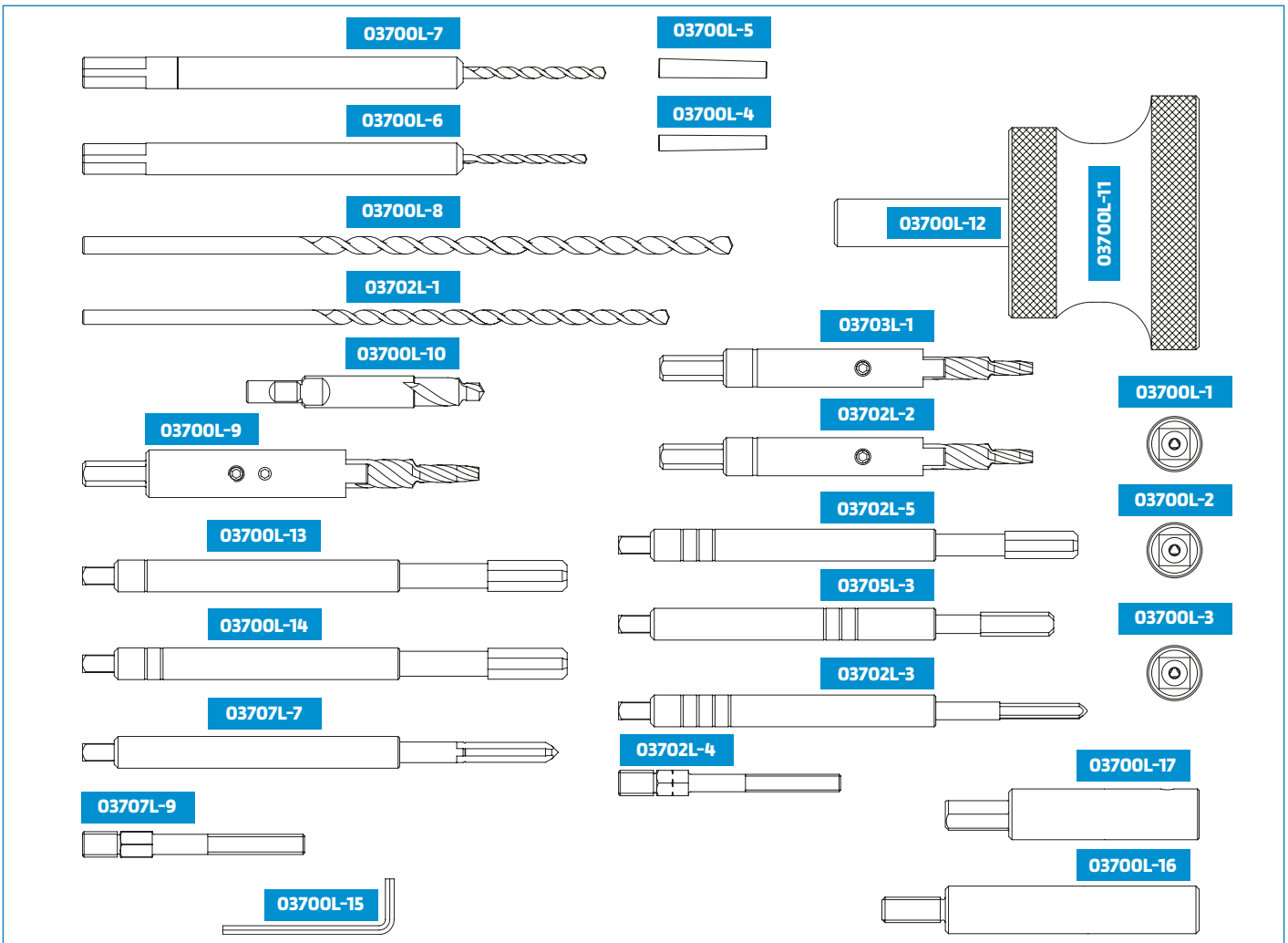

**⚠ Se necessario (ingombro del motore) utilizzare la prolunga per perno di estrazione codice 03700L-16.**















- Avvitare l'inserto filettato per l'estrazione alla candelecca e procedere con la fase di estrazione agendo sulla massa battente (fig. 8 rif. A)
- Procedere con l'inserimento della candelecca nuova (fig. 9)



## COMPONENTES

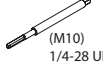
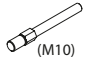

Ref.	Descripción	
03700L-1	Casquillo de extracción con rodillos Ø 2.5 mm	
03700L-2	Casquillo de extracción con rodillos Ø 3,5 mm	
03700L-3	Casquillo de extracción con rodillos Ø 4 mm	
03700L-4	Tubo guía para perforación Ø 2.7 mm	
03700L-5	Tubo guía para perforación Ø 3,6 mm	
03700L-6	Prolongación + punta Ø 2.7 mm	
03700L-7	Prolongación + punta Ø 3,6 mm	
03700L-8	Punta helicoidal cilíndrica Ø 5.5 mm	
03700L-9	Prolongación + punta Ø 8.9 - Ø 5.5 mm	
03700L-10	Punta dos diámetros Ø 8.9 - Ø 5.5 mm corta	

Ref.	Descripción	
03700L-11	Extractor de percusión	
03700L-12	Perno M8 para ranura	
03700L-13	Macho M10x1	 M10x1
03700L-14	Macho M10x1.25	 M10x1.25
03700L-15	Llave de cadena 2.5 mm	
03700L-16	Prolongación Ø 15 mm para perno de extracción	
03700L-17	Prolongación Ø 16 mm con pasador para portapunta	
03702L-1	Punta helicoidal cilíndrica Ø 4.5 mm	
03702L-2	Prolongación + punta Ø 8 - Ø 4.5 mm	 M9
03702L-3	Macho 12-28	 (M8) 12-28 UNF
03703L-1	Prolongación + punta Ø 7 - Ø 4.5 mm	 M8
03702L-4	Inserto roscado 12-28	
03702L-5	Macho M9x1	 M9x1
03707L-7	Macho 1/4" - 28	 (M10) 1/4-28 UNF
03707L-9	Inserto roscado 1/4"	 (M10) 1/4-28 UNF
03705L-3	Macho M8x1	 M8x1

La bujía debe poder resistir altas temperaturas, elevadas presiones, vibraciones y conexión de agentes corrosivos que se desarrollan durante la combustión.

La punta de la bujía debe ser posicionada con mucha precisión para inflamar el carburante.

No debe penetrar demasiado en profundidad dentro de la cámara de combustión porque podría iniciar la combustión incorrectamente.

Por estos motivos, la sustitución es problemática, y las bujías se rompen fácilmente en su sede.

• Especificaciones de uso:

Cota A  $\geq$  14 mm (M10)

Cota A  $\geq$  20 mm (M9, M8)

Cota L  $\leq$  13 mm

• L (rosca)

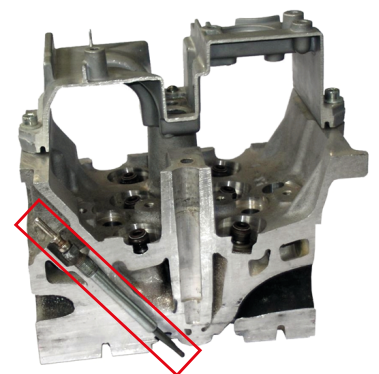
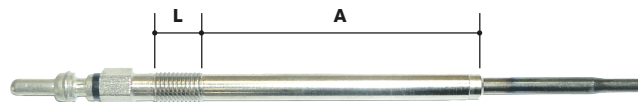

**⚠ EL USO DE ESTE EQUIPO EXIGE ATENCIÓN Y CUIDADO AL POSICIONAR EL EJE DE LA BUJÍA PARA EVITAR PROBLEMAS EN LA CABEZA Y TAMBIÉN PARA EVITAR EL RIESGO DE ROTURA DE HERRAMIENTAS; PUEDE AYUDAR TOMAR COMO REFERENCIA LA INCLINACIÓN DE LA BUJÍA ADYACENTE (LAS DIFERENCIAS PEQUEÑAS:  $\pm$  5° NO TIENEN UN IMPACTO SIGNIFICATIVO EN EL RESULTADO FINAL).**

**IMPORTANTE** - En fase de perforación con la broca de dos diámetros (para remover la parte superior roscada de la bujía), para conservar la calidad de la broca y aumentar su durabilidad, obligatoriamente hay que atenerse a las siguientes indicaciones

1) Número de revoluciones MÁX de trabajo: 200 revoluciones/min.

2) Después de pocos mm. de profundidad de perforación (1+3 mm), quitar la broca y limpiarla con aceite de corte, luego soplar en el alojamiento de la bujía para eliminar la viruta de metal.

Seguir perforando de esta manera hasta remover completamente la parte roscada de la bujía.

## PROCEDIMIENTO:

Todas las fases que se describen a continuación deben efectuarse con el máximo cuidado, precisión y atención

- Use el casquillo de extracción con rodillos adecuado (entre las tres suministradas,  $\varnothing 2,5 - \varnothing 3,5 - \varnothing 4$ ) para quitar la parte terminal del electrodo de la bujía (fig. 1).

Códigos de referencia: 03700L-1, 03700L-2, 03700L-3

Herramientas necesarias: Llave  $\square 3/8"$

- Si fuera necesario, en caso de que quedara parte del electrodo central, tome el tubo guía cónico (entre los dos suministrados, con orificio interno  $\varnothing 2,7 - \varnothing 3,6$ ) e introdúzcalo en la parte de electrodo restante (fig. 3).

Códigos de referencia: 03700L-4, 03700L-5

- Utilice la prolongación + punta adecuada (entre las dos suministradas, con punta  $\varnothing 2,7$  o  $\varnothing 3,6$ ) para quitar la parte de electrodo restante (fig. 3).

Códigos de referencia: 03700L-6, 03700L-7

Herramientas necesarias: Taladro eléctrico / neumático

- Realice el preorificio para la extracción de la bujía (fig. 4) usando la punta helicoidal cilíndrica larga  $\varnothing 5,5$  (M10) o  $\varnothing 4,5$  (M9, M8) incluida en el kit.

Códigos de referencia: 03700L-8, 03702L-1

Herramientas necesarias: Taladro eléctrico / neumático

- Use la prolongación + punta de 2 diámetros y comience la operación de perforación, tomando la precaución de perforar en pequeños tramos ( $1-2$  mm) y sople para eliminar las virutas metálicas, hasta que la punta alcance el tope de parada y se haya extraído completamente la parte roscada de la bujía.

De esta manera, habrá quitado la parte superior de la bujía (fig. 5).

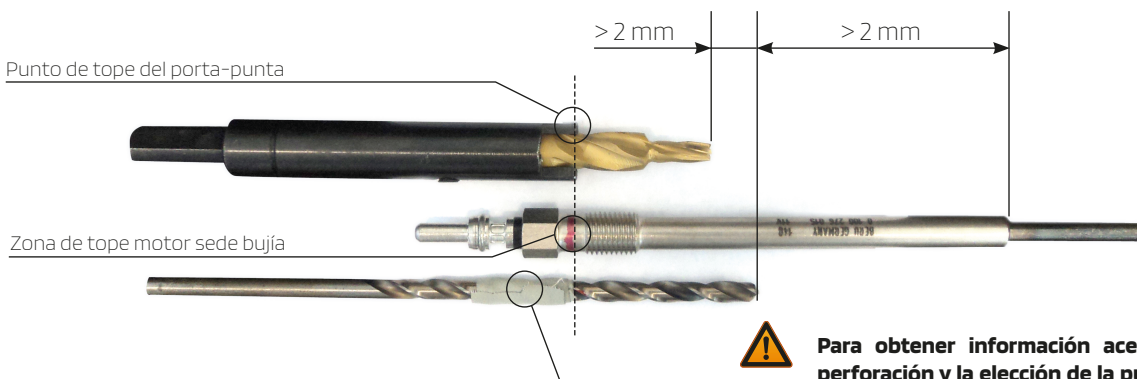
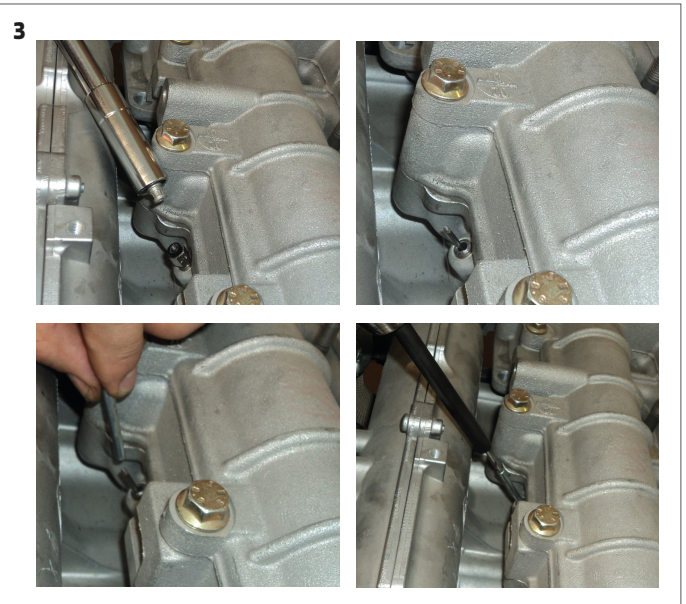
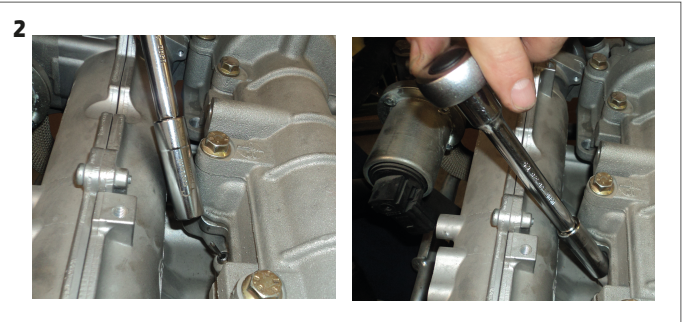
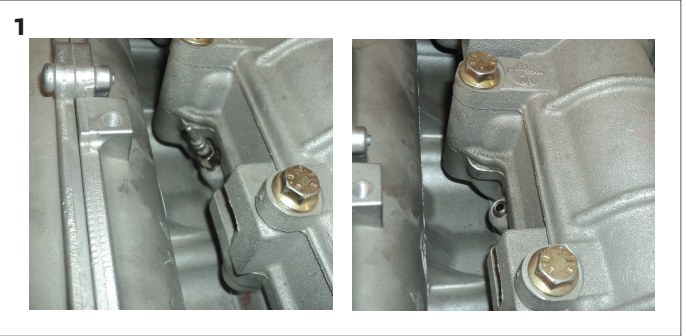

**Para obtener información acerca de la profundidad de perforación y la elección de la punta de 2 diámetros (para la fase sucesiva) siga el esquema indicado a continuación. Para obtener un punto límite de referencia para la profundidad de perforación, se aconseja utilizar cinta adhesiva.**

Códigos de referencia: 03700L-9 (+03700L-10), 03702L-2, 03703L-1

Herramientas necesarias: Taladro eléctrico / neumático

**⚠ Si fuera necesario (dimensiones totales del motor) use la prolongación para portapunta código 03700L-17.**

- Use el macho  $\frac{1}{4}$  -28 UNF (M10) o 12-28 UNF (M9, M8) + prolongación y comience la operación de roscado manual para la extracción de la bujía (fig. 6)

Códigos de referencia: 03707L-7, 03702L-3

Herramientas necesarias: Llave fija de gancho

- Para renovar la rosca para la nueva bujía que será montada, use el macho + prolongación incluida (fig. 7):
  - M10x1
  - M9x1
  - M10x1,25
  - M8x1

Códigos de referencia: 03700L-13, 03700L-14, 03702L-5, 03705L-3

Herramientas necesarias: Chiave a cricchetto

**⚠ Una vez renovada la rosca para la nueva bujía, limpie la sede con aire comprimido para eliminar la suciedad y/o los residuos de material.**

- Una vez preparada la rosca para la nueva bujía, enrosque el inserto roscado  $\frac{1}{4}$  -28 UNF (M10) o 12-28 UNF (M9, M8) para la extracción en el perno con orificio roscado M8 (con el extractor de percusión montado) (fig. 8)

Códigos de referencia: 03707L-9, 03700L-12, 03700L-11, 03702L-4

Herramientas necesarias: Llave combinada CH-8;  
Llave hexagonal CH-6

**⚠ Si fuera necesario (dimensiones totales del motor) use la prolongación para perno de extracción código 03700L-16.**

- Enrosque el inserto roscado para la extracción de la bujía y proceda con la fase de extracción actuando sobre el extractor de percusión (fig. 8 ref. A)
- Introduzca la nueva bujía (fig. 9)

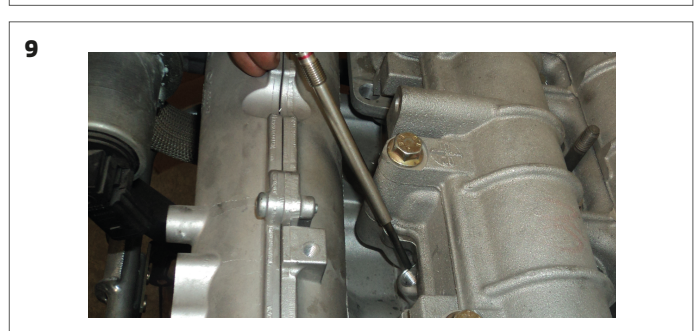
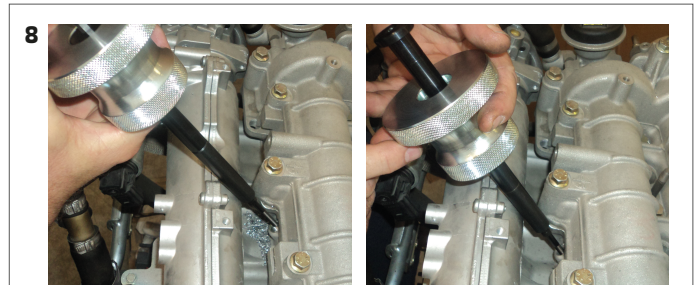
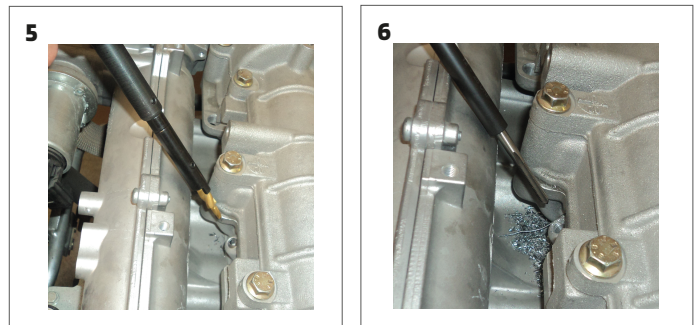
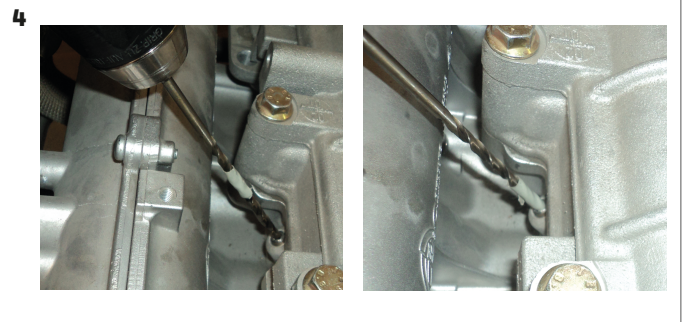





**SW STAHL**  
PROFESSIONAL TOOLS

**SW-STAHl GMBH**

An der Hasenjagd 3 • D-42897 Remscheid  
Telefon: +49 2191 464380 • Fax: +49 2191 4643840  
[www.swstahl.de](http://www.swstahl.de) • [info@swstahl.de](mailto:info@swstahl.de)